



## **ADJUSTABLE SHOWER BASE**

### **WSB-09**

- Components
- Installation
- Maintenance
- Warranty

# Components

---

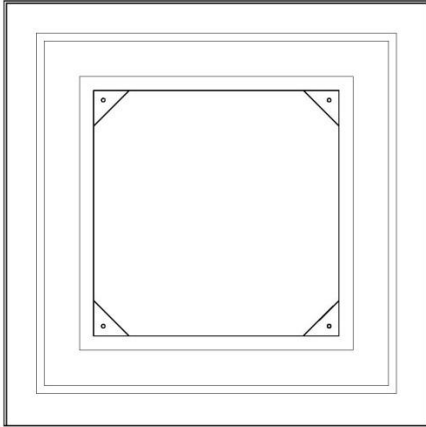

Outer Base

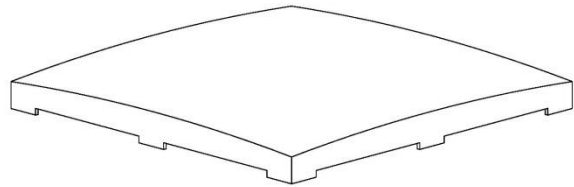

Insert Cap

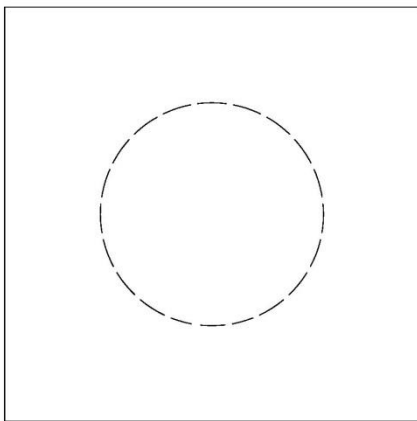

Clear Pan

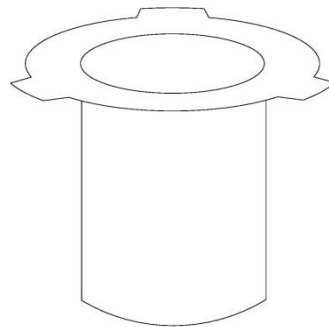

Adaptor

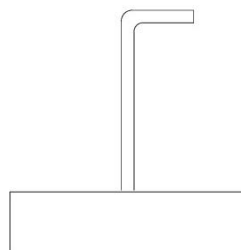

Hook & Handle / Height Gauge

# Installation

(A full video of installation is available at [www.wydaflo.com](http://www.wydaflo.com))

- 1** Cut the drainage pipe flush to the top of the floor. For timber floors reinforce the pipe with two button head screws to prevent retraction, this is not necessary in concrete. For 100mm pipe a reducer and sleeve is required. The reducer must be glued to its maximum depth.

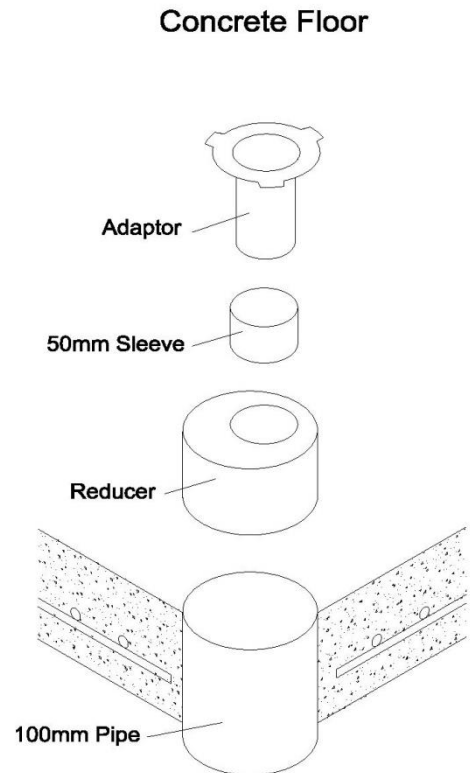
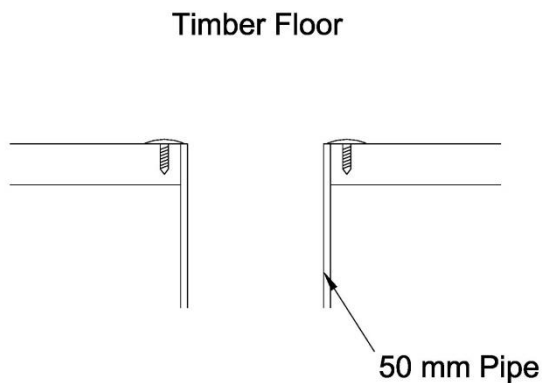

- 2** Prepare the floor area below the base ensuring it is level and flat. Position the outer base and ensure the outlet will be within the adjustment zone shown on the clear pan. Place some silicone between the floor and the internal corners before fixing the outer base to the floor with the masonry anchors or screws provided.

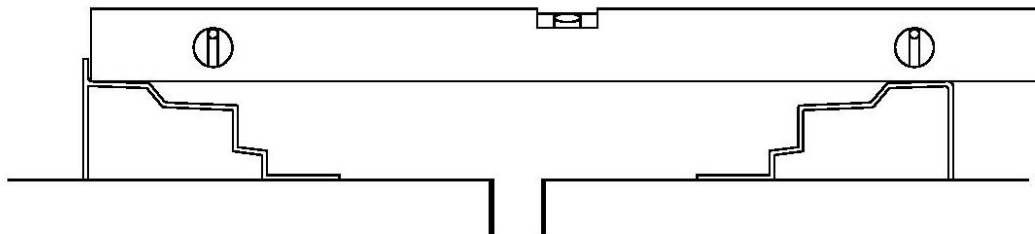

- 3** Prime the waste pipe and the adaptor. Apply PVC cement (glue) to the pipe and adaptor. Insert the adaptor, place the supplied hook and handle on top of the adaptor to act as a height gauge then use the clear pan as a straight-edge to provide 17 mm of fall.

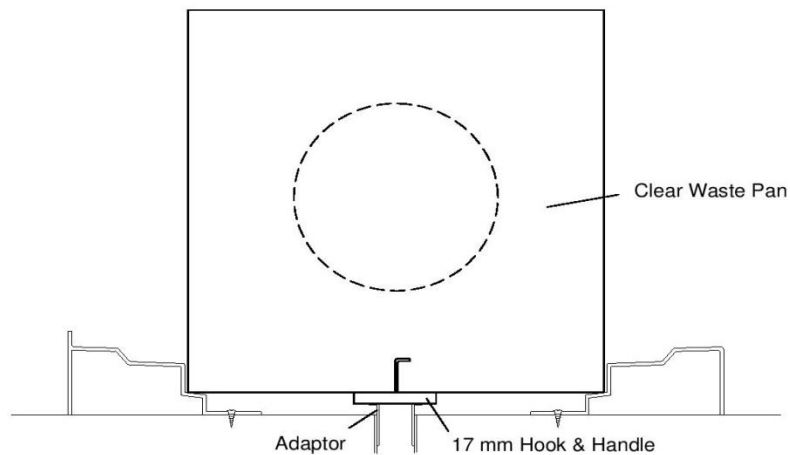

- 4** Drop in the clear pan. Push the pan down to the adaptor as you visually drill 2.5mm holes through the pan and the adaptor lugs, also drill a hole in the centre of the adaptor outlet. Keep pushing down, drill 2.5mm perimeter holes through the pan and collar in all four corners of the outer base. Note, when drilling the corner holes through the collar, slightly lean your drill inwards to ensure the screws will be seated square to the collar.

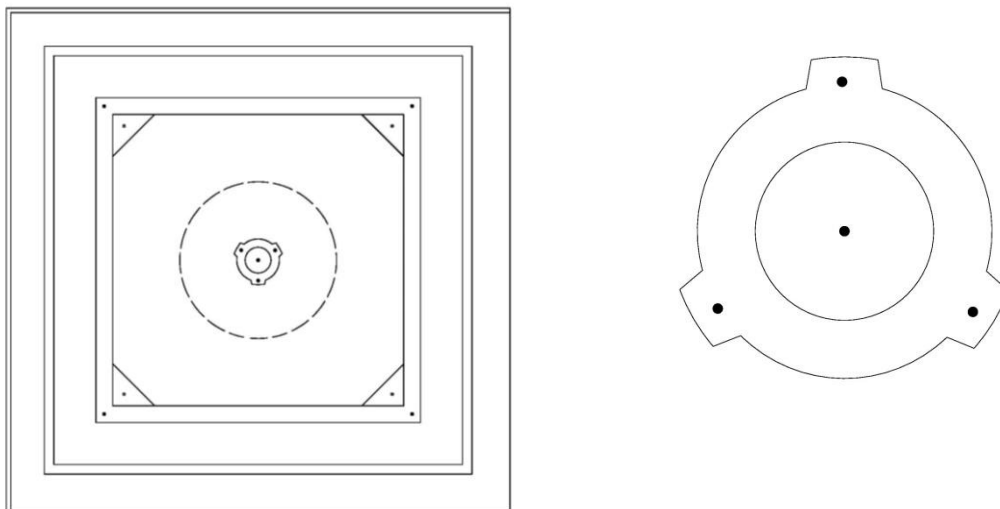

- 5** Hook out the clear pan and expand all predrilled holes in the clear pan to 4.5mm. Enlarge the centre outlet hole with a 38mm hole saw. Remove all plastic shavings from the adaptor pan and collar where drilling has occurred.
- 6** Clean all adjoining surfaces that accept silicone with a clean cloth moistened with mineral turpentine then wipe with a clean dry cloth. Apply a thick generous bead of low modulus neutral cure silicone to the top of the adaptor and the collar of the outer base.

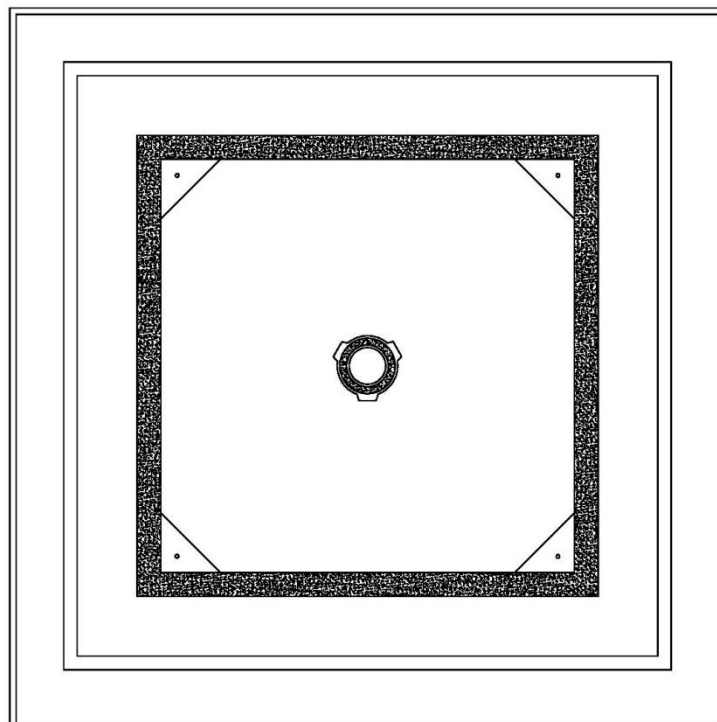

- 7** Return the waste pan to align with the predrilled holes, push the pan down in the corners then push it down to the adapter. Hand-tighten all three adaptor screws alternating from one to the other until the pan rests on the adapter. Firm the perimeter of the clear pan by pushing down around the perimeter. Hand-tighten corner screws until firm.
- 8** Place the insert into the outer base. Installation is complete.

# Maintenance

---

- All Wydaflo products can be cleaned using a soft cloth and warm water, soap or a suitable household detergent. Always rinse off cleaners within five minutes of application. Never use a scouring cloth or other abrasive object to clean the product.
- If required, the insert cap can be removed using the supplied removal hook.
- If accidental scratches, abrasions or burns occur, the surface finish may be restored by gentle polishing with an emulsion based plastics cleaner.
- **Installation tips**
  - Use low modulus neutral cure premium grade sealants.
  - Thoroughly clean adjoining surfaces that accept sealant.
  - Apply sealant generously paying attention to the corners.
  - When drilling into plastic use your drill on low speed.
  - Tighten fixing screws by hand until the screws sit firm only.

## Product Warranty

---

Wydaflo Pty Ltd offers a 2 year replacement guarantee if a fault occurs in any Wydaflo product solely caused by faulty manufacturing techniques or material fault. This guarantee is subject to correct installation and maintenance procedures being undertaken and does not include costs of installation or removal of the product. To make a claim your original receipt, contact details and details of the claim; including installers details, installation date and an overview of the defects identified in the product must be provided. The warranty applies to the original purchaser and is non-transferable.

Licensed plumbers can upgrade to a 5 year Warranty period by emailing [admin@wydaflo.com](mailto:admin@wydaflo.com) providing License number, place and date of purchase and installation.

## Helpline

---

For installation support and advice contact Wydaflo.

- Website: [www.wydaflo.com](http://www.wydaflo.com)
- Email: [admin@wydaflo.com](mailto:admin@wydaflo.com)
- Phone: +61 4 2894 1446
- Business Hours: 7:00am – 4:00pm Monday to Friday,  
7:00am – 12:00 noon Saturday.  
*Australian Eastern Standard Time.*

**Keep this manual for future reference.**

The information contained within this manual is provided as a guide only. It is intended for use by persons having knowledge of this technical area, at their own discretion and risk. Wydaflo Pty Ltd assumes no responsibility for results obtained or damage incurred from the use of this material in whole or by part by the installer.